

Livingstone Range School Division No.68

10-Year Planning Priorities (2016-2026)

3-Year Capital Plan (2017-2020)

Approved By the Board of Trustees: _____



Livingstone Range
SCHOOL DIVISION NO. 68

Livingstone Range School Division No.68

PO Box 69

5202 - 5th Street East

Claresholm, AB T0L 0T0

Phone: (403) 625-3356

www.lrsd.ca

Table of Contents	0.0
Executive Summary	1.0
Enrollment Trends	2.0
Planning Priorities	
- J.T. Foster School Modernization (7-12)	3.1
- Livingstone School Modernization	3.2
- Pincher Creek Schools	3.3
- Canyon Elementary School Modernization	
- Matthew Halton Community School Modernization	
- A.B. Daley Community School Modernization	3.4
- Crowsnest Pass Schools	3.5
- Stavelly School	3.6
- Granum School	3.7
Three-Year Capital Plan Requests	
Appendix	

Prepared by:



915 . 15 Street South, Lethbridge, Alberta T1J 3A5
 403.327.3113 | office@fwbarch.com | www.fwbarch.com
 1, 564 South Railway Street, Medicine Hat, AB T1A 2V6
 403.527.8111 | office@fwbarch.com | www.fwbarch.com
 200, 908 . 17 Avenue SW, Calgary, Alberta T2T 0A3
 403.264.3133 | office@fwbarch.com | www.fwbarch.com



Executive Summary

In developing these 10-Year Capital Planning Priorities, and 3-Year Capital Plan, the Board of Trustees is guided at all times by the Core Values, Vision, Mission, and Guiding Principle of the Livingstone Range School Division No.68

The School Division's Vision Statement, "To be leaders in providing quality education to rural students in a dynamic learning environment" has been the corner stone of the development of this plan.

As a rural School Division we are not alone in the province in grappling with decreasing enrollment and facility utilization numbers across the communities we serve. The priorities developed as a part of this plan are intended to improve the sustainability of our facility operations and maintenance, and to improve the viability and diversity of programming that can be made available to the students we serve.

The Board was asked to consider possible scenarios to achieve these goals based on historical enrollment data. In consultation with senior administration, the Board agreed that the priorities for the 10-Year Capital Plan would be:

- J.T. Foster School Modernization (7-12)
- Livingstone School Modernization
- Pincher Creek Schools
 - Canyon Elementary School
 - Matthew Halton Community School
- A.B. Daley Community School Modernization
- Crowsnest Pass Schools
 - Review to consider combining Horace Allen School and Isabelle Sellon School
 - Crowsnest Consolidated High School
- Stavely School
- Granum School

A Value Scoping Session was completed in 2016 to review the earlier proposed 'Nanton Schools Solution' in greater detail. It is expected that J.T. Foster School Modernization (7-12), the Livingstone School Modernization, and the Pincher Creek Schools project will be started within the 2017-2020 Capital Plan.



The following are the Divisional Enrollment Trends for Livingstone Range School Division No.68.

LIVINGSTONE RANGE SCHOOL DIVISION NO. 68
September 30th Historical Enrollment Count

Year	FTE	Chg
1995	4,972.0	
1996	4,895.0	-1.5%
1997	4,934.5	0.8%
1998	4,918.0	-0.3%
1999	4,827.0	-1.9%
2000	4,743.0	-1.7%
2001	4,598.0	-3.1%
2002	4,488.0	-2.4%
2003	4,353.0	-3.0%

Year	FTE	Chg
2004	4,337.0	-0.4%
2005	4,195.0	-3.3%
2006	4,095.0	-2.4%
2007	3,901.0	-4.7%
2008	3,845.0	-1.4%
2009	3,785.0	-1.6%
2010	3,669.5	-3.1%
2011	3,616.0	-1.5%
2012	3,529.5	-2.4%

Year	FTE	Chg
2013	3,446.5	-2.4%
2014	3,395.0	-1.5%
2015	3,395.5	0.0%
2016	0.0	0.0%
2017	0.0	0.0%
2018	0.0	0.0%
2019	0.0	0.0%
2020	0.0	0.0%
2021	0.0	0.0%

September 30th Historical Enrollment Count

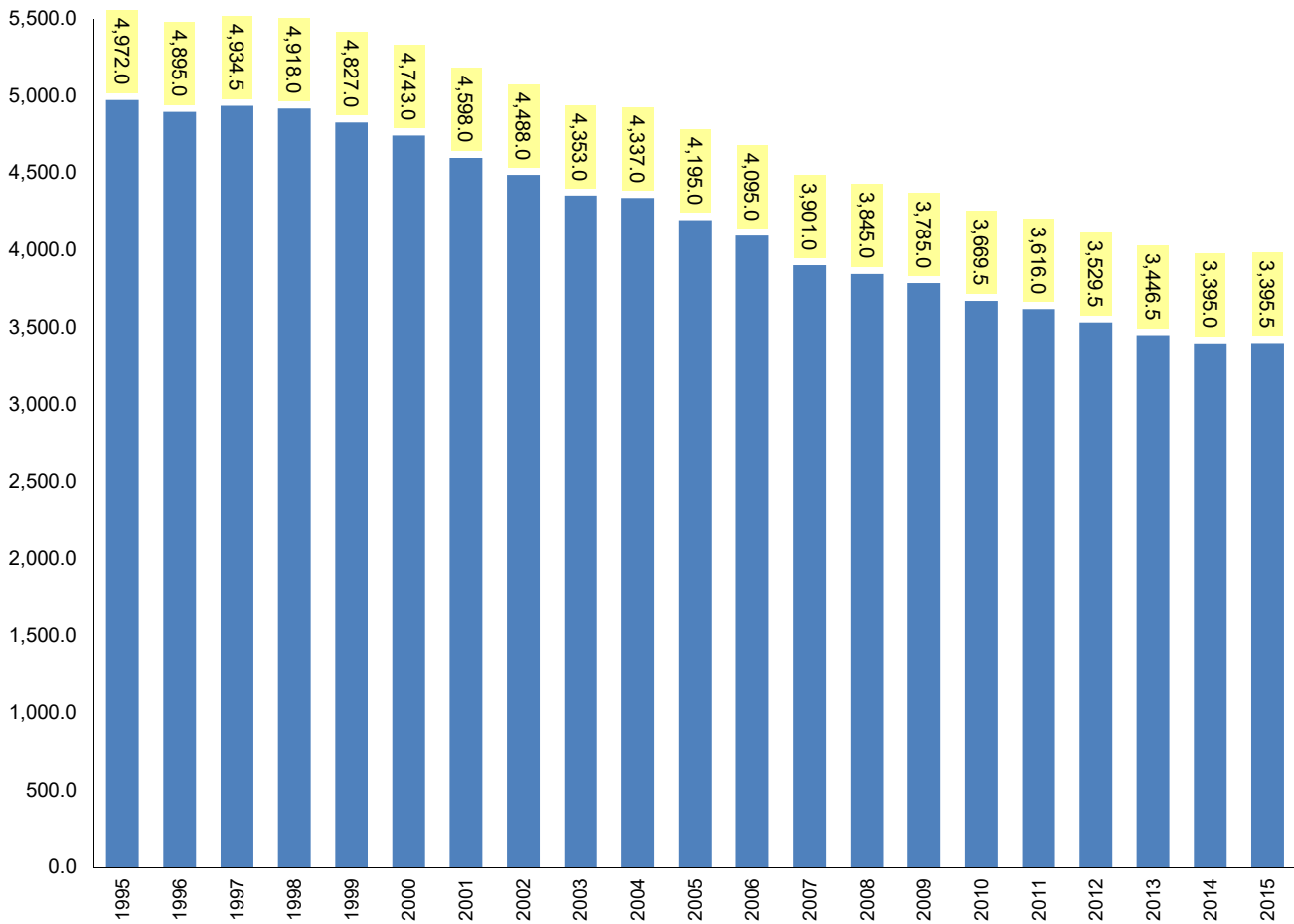

ENROLLMENT TRENDS



3.0 - PLANNING PRIORITIES

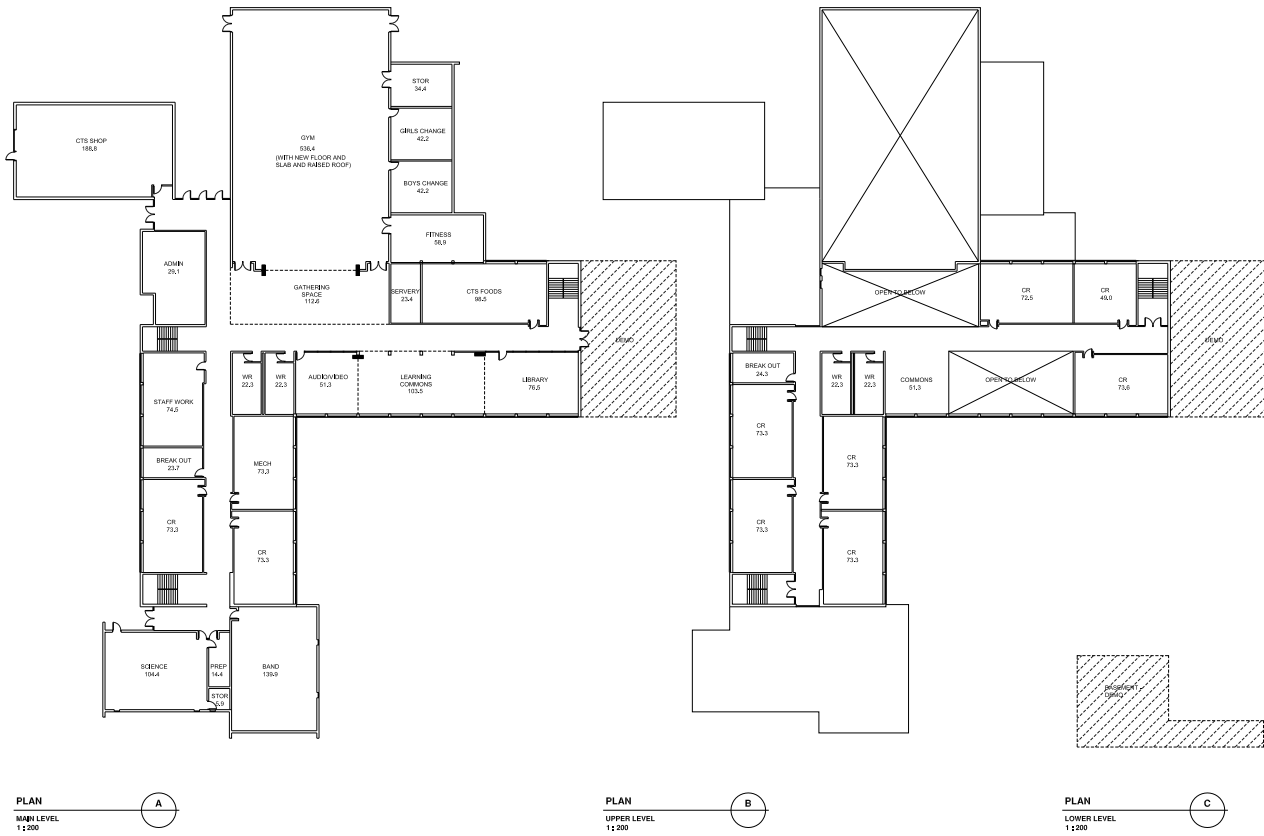

Estimated Capital Cost: \$10,268,603

Hard Construction Cost: \$8,751,075 | Soft Costs: \$1,365,775 | Non-refundable GST: \$151,752

Project Summary

J.T. Foster School was originally constructed in 1963, and has had a series of additions completed through the 1970s. A renovation of the facility's CTS lab was completed in 2009 to facilitate the District's mobile CTS program.

The modernization is intended to right-size J.T. Foster School as a Grade 7-12 facility. The modernization must address serious building systems issues identified in the lower level of the facility, and detailed in the Structural and Electrical Engineering reports included in the appendix of this Capital Plan. In addition the intent of the modernization is to raise the roof of the gymnasium, and remove/replace the floor slab to allow for installation of a sprung floor system, more appropriate to a junior/senior high school facility.

Timeframe

Following the Value Scoping in April, 2016, if design funding were to come available for this project in 2017, the project would be expected to be complete for the 2019 school year.

Key Points:

- The modernization of J.T. Foster School will address serious structural and electrical building system issues which will have a negative impact on the long-term integrity of the school facility.
- The concrete slab subfloor in the existing Gymnasium at J.T. Foster School needs to be addressed as this presents a health and safety issue in a 7-12 school facility.

Building ID: B3819A

FCI: 16.21%

Replacement Cost: \$13,255,000

Grade Configuration:

Current: 7-12

Proposed: 7-12

Area: Current: 4,327m²
Proposed: 3,615m²

Enrollment: 2016: 204
2015: 213
2014: 203

Capacity: Current: 530 (40% ACU)
Proposed: 250 (87% ACU)

Livingstone School Modernization, Lundbreck

The Livingstone School was originally built in 1902, though that portion of the facility has since been completely demolished and over-built. Additions were completed in 1959 and 1968, and in 1992, along with the removal of the original building, an addition and modernization were completed.

Educational Benefit

The existing Livingstone School is comprised of a series of double-loaded corridors providing circulation to the U-shaped school footprint, with traditional classroom and ancillary spaces on each side. The proposed modernization will allow for the development of a Learning Commons, to enhance programming for literacy and numeracy; and a series of collaborative learning spaces to facilitate programming in support of Inspiring Education mandates.

Infrastructure Benefit

This modernization will address outstanding maintenance items, including mechanical and electrical system upgrades and repair and remediation of the existing building envelope.

The planned modernization will also consider possibilities for right-sizing the school facility to improve operations and maintenance efficiencies for the School Division.

Partnerships

Livingstone Range School Division will continue to work with the Hamlet of Lundbreck, and the M.D. of Pincher Creek to establish possible partnerships to enhance the facility as a part of a future school modernization.

Timeframe

A Value Scoping Session for this project should be carried out in late-2017 to properly establish the parameters and budget for the modernization. It is hoped that complete design funding would be available by late-2018, with the modernized facility ready for occupancy for fall, 2020.

Key Points:

- A Value Scoping Session will be requested for late-2016 to establish the required project scope.
- **The existing school facility is quite cellular and a full facility modernization will allow for more open, flexible, and collaborative learning environments.**
- The proposed modernization will address technology short comings in the existing facility by improving access to WiFi and Internet, as well as improving environmental conditions through improved HVAC systems.

Estimated Project Cost: \$9,135,000

Hard Construction Cost: \$7,500,000 | Soft Costs: \$1,500,000 | Non-refundable GST: \$135,000



Building ID: B9361A
FCI: 15.61%
Replacement Cost: \$10,601,779
Grade Configuration:
 Current: K-12
 Proposed: No Change
Area: Current: 3,130m²
 Proposed: TBC at Value Scoping
Enrollment: 2016 (Projected): 173.5
 2015: 172
 2014: 180.5
Capacity:
 Current: 328 (51% utilization)
 Proposed: TBC at Value Scoping



Canyon Elementary School

Building ID: B3871A

FCI: 7.06%

Replacement Cost: \$14,395,000

Grade Configuration:

Current: K-6

Proposed: TBC at Value Scoping

Area: Current: 4,274m²

Proposed: TBC at Value Scoping

Enrollment: 2016 (Projected): 245

2015: 248.5

2014: 247

Capacity:

Current: 531 (44% utilization)

Proposed: TBC at Value Scoping



Matthew Halton Community School

Building ID: B3874A

FCI: 4.00%

Replacement Cost: \$21,477,716

Grade Configuration:

Current: 7-12

Proposed: TBC at Value Scoping

Area: Current: 6,340m²

Proposed: TBC at Value Scoping

Enrollment: 2016 (Projected): 266

2015: 271

2014: 285

Capacity:

Current: 700 (38% utilization)

Proposed: TBC at Value Scoping

Estimated Project Cost: TBC

Hard Construction Cost: | Soft Costs: | Non-refundable GST:

Project Summary

Serving the community of Pincher Creek, both Canyon School and Matthew Halton School are shown to be in good condition, though both school facilities are somewhat dated in their availability of open, collaborative learning environments, and the availability of power and IT infrastructure.

Critically though, both school facilities suffer from chronically low utilization rates which need to be addressed to ensure the long-term sustainability and viability of operations and maintenance, as well as educational programming for the community of Pincher Creek

Operational Benefit

Facilities modernizations, including the possibilities of right-sizing each facility, and/or consideration of grade reconfigurations, will for improved sustainability of the operations and maintenance of these facilities within the current funding models.

Timeframe

A Value Scoping Session for Pincher Creek should be carried out in late-2018 to properly establish the scope and budget for these projects. If funding were made available by early-2019, modernized facilities could ready for occupancy for the 2021 school year



Key Points:

- A Value Scoping Session was undertaken in April, 2016 and identified options that included modernization of A.B. Daley School.
- Low utilization rates at A.B. Daley will be addressed through the right-sizing.

Estimated Project Cost: TBC

Hard Construction Cost: | Soft Costs: | Non-refundable GST:

Project Summary

A.B. Daley Community School offers valuable existing educational infrastructure that needs to be leveraged as a part of any modernization and right-sizing considered for the facility. As a Community School, A.B. Daley has impressive Gym, Music, and Library Space which add to the combined potential of this project.

Partnerships

Discussions have begun already with two Open Houses held in Nanton to gather community input ahead of the planned Value Scoping, and to gauge the partnership potential for enhanced facilities to be developed as a part of these facility modernizations.

Building ID: B3818A

FCI: 8.16%

Replacement Cost: \$11,716,000

Grade Configuration:

Current: K-6

Proposed: TBC

Area: Current: 3,630m²

Proposed: TBC

Enrollment: 2016: 219

2015: 193

2014: 198.5

Capacity:

Current: 352 (54% utilization)

Proposed: TBC

Horace Allen School
Building ID: B2970a
FCI: 6.94%
Replacement Cost: \$12,265,464

Grade Configuration:
 Current: K-3
 Proposed: n/a

Area: Current: 3,683m²
 Proposed: n/a

Enrollment: 2016 (Projected): 210
 2015: 205.5
 2014: 186.0

Capacity:
 Current: 387 (53% utilization)
 Proposed: TBC at Value Scoping

Isabelle Sellon School
Building ID: B2458A
FCI: 9.38%
Replacement Cost: \$12,447,584

Grade Configuration:
 Current: 4-6
 Proposed: TBC at Value Scoping

Area: Current: 3,893m²
 Proposed: TBC

Enrollment: 2016 (Projected): 157
 2015: 149
 2014: 136

Capacity:
 Current: 367 (41% utilization)
 Proposed: TBC at Value Scoping

Crowsnest Consolidated
Building ID: B2969A
FCI: 5.97%
Replacement Cost: \$24,103,510

Grade Configuration:
 Current: 7-12
 Proposed: No Change

Area: Current: 6,831m²
 Proposed: TBC

Enrollment: 2016 (Projected): 290
 2015: 302
 2014: 307

Capacity:
 Current: 682 (40% utilization)
 Proposed: TBC at Value Scoping



Estimated Project Cost: TBC

Hard Construction Cost: | Soft Costs: | Non-refundable GST:

Project Summary

Horace Allen, Isabelle Sellon, and Crowsnest Consolidated High Schools together serve the greater community of the Municipality of Crowsnest Pass. All three school facilities are in good condition having been modernized in the early 2000s. These school facilities already incorporate some open, flexible learning spaces, but do require improved access to electrical and IT infrastructure in order to better accommodate today's educational trends.

As has been discussed for other communities served by Livingstone Range School Divisions, all three schools are effected by chronically low utilization rates. This under-utilization of the existing infrastructure in the Crowsnest Pass needs to be addressed to ensure the long-term sustainability and viability of operations and maintenance for the School Division. As well, educational programming and the ability to leverage full value from the existing infrastructure in these communities would be improved if utilization rates were addressed.

We are proposing that consideration be given to combining Horace Allen School and Isabelle Sellon School, with a grade reconfiguration to K-6. A facility expansion would likely be required to accommodate this reconfiguration.

Timeframe

A Value Scoping Session for the Crowsnest Pass should be carried out to properly establish scope and budget.



Estimated Project Cost: TBC

Hard Construction Cost: | Soft Costs: | Non-refundable GST:

Project Summary

The Stavelly School was originally constructed in 1957 and underwent a full facility modernization in 2002. The School already benefits from a partnership with the local community through a shared Library Facility.

It is suggested that a Community Round Table be held in Stavelly to develop programmatic goals in the 2018-2019 school year. Following this, a Community meeting could be held to discuss the existing facility, and the possibility of improving the ability of the school infrastructure to be leveraged by the School Division and Stavelly School administration towards the community's programmatic goals.

Building ID: B4099A

FCI: 4.60%

Replacement Cost: \$3,598,904

Grade Configuration:

Current: K-6

Proposed: No Change

Area: Current: 1,175m²

Proposed: TBC

Enrollment: 2016 (Projected): 82

2015: 67.5

2014: 64

Capacity:

Current: 89 (78% utilization)

Proposed: TBC



Estimated Project Cost: TBC

Hard Construction Cost: | Soft Costs: | Non-refundable GST:

Project Summary

The Granum School is a new school facility constructed in 2003. The facility is currently in excellent condition as a result of its age and a well-managed maintenance program. Currently discussions are underway between the School Division and the Granum Library Board to begin the development of a shared Community Library Space within the School. The partnership will have the benefit of improving Library service for both the school and community, as well as contributing to the operational costs of this under-utilized facility.

It is suggested that a Community Round Table be held in Granum to develop programmatic goals in the 2019-2020 school year.

Building ID: B3515B

FCI: 0.82%

Replacement Cost: \$8,281,055

Grade Configuration:

Current: K-9

Proposed: No Change

Area: Current: 2,099m²

Proposed: TBC

Enrollment: 2016 (Projected): 79.5

2015: 72.5

2014: 73.5

Capacity:

Current: 207 (32% utilization)

Proposed: TBC

Summary

The Board has used the following as its guide in the preparation of the 2017-2020 Capital Plan, within this overall 10-Year Capital Planning document.

- A review of the Mission, Vision, and Values of the School Division
- The School Divisions previous Capital Planning priorities
- Past Enrollment and Utilization Data
- School Facility Audits

School Facility	Completion Year	Estimated Cost
J.T. Foster School Modernization (7-12)	2019	\$10,268,603
Livingstone School Modernization	2020	\$ 9,135,000
Pincher Creek Schools	2022	TBC

Enrollment trends have been considered in the development of all of the proposed Capital Planning Priorities in this document. Based on current projections, we have developed this 10-Year Capital Plan to ensure that requirements for students spaces not only take into account the anticipated 10-year enrollment trend, but also anticipate continued trends, beyond the 10-year projections, based on currently available information.

Livingstone Range School Division's Capital Plan:

- Ensures schools are right-sized for the educational needs of our students;
- Addresses programming needs and the responsible leveraging of existing infrastructure in our communities through the modernization and right-sizing of existing facilities;
- Addresses student safety both within and outside of school buildings;
- Provides facility space to meet the provincial small class initiative;
- Provides educational spaces that will meet the needs of 21st Century learners.





APPENDIX



November 19, 2015

Livingstone Range School Division No. 68
5202 – 5 Street East
PO Box 69
Claresholm, AB T0L 0T0

ISSUED FOR USE
FILE: ENG.LGEO03028-01.001
Via Email: gorzitzag@lrsd.ab.ca

Attention: Mr. Greg Gorzitza

Subject: JT Foster School
Concrete Evaluation
Nanton, Alberta

1.0 INTRODUCTION

Tetra Tech EBA Inc. (Tetra Tech) was retained by Livingstone Range School Division No. 68 to conduct a concrete evaluation at the JT Foster School, located in Nanton, Alberta. The goal of the investigation was to assess condition of the concrete walls and slab in the Mechanical Room and to provide a feasibility assessment for the future upgrades/ rehabilitation of the school. The scope of the concrete evaluation is as follows:

- Site inspection and coring of concrete,
- Laboratory testing of the retained samples, to include:
 - Concrete compressive strength
 - Petrographic analysis
- Engineering analysis of the site conditions and laboratory test results to determine the condition of the concrete.

This report presents the results of the forensic concrete investigation, including the site inspection, laboratory testing, and engineering analysis undertaken by Tetra Tech.

2.0 SITE INVESTIGATION

The site was visited on November 6, 2015 by a Tetra Tech representative for photographic documentation and coring.

The mechanical room floor was wet in most areas, and moisture had wicked up the walls in the room. Crystalline deposits consistent with the precipitation of salts were observed on the floor. Trace crystalline deposits were also observed on the lower portion of the walls.

The deposits are consistent with groundwater moisture infiltration, carrying water soluble salts through concrete where they precipitate and accumulate within the building.

The most prevalent form of deterioration noted in the mechanical room was the loss of paint and trace concrete delamination within the lower portion of the concrete walls.



Photo 1: Crystalline salt deposits on floor slab and lower portion of walls



Photo 2: Crystalline salt deposits on floor slab and lower portion of walls



Photo 3: Crystalline salt deposits on floor slab and lower portion of walls and mechanical equipment



Photo 3: Crystalline salt deposits on floor slab and lower portion of walls

3.0 LABORATORY ANALYSIS

Six concrete cores were collected EBA for analysis from the mechanical room walls and floor slab. Examination of the concrete cores began with photographic documentation and initial visual observations, followed by more detailed petrographic analyses in general accordance with American Society for Testing and Materials (ASTM) C856.

The cores were tested for hardened density and compressive strength in accordance with Canadian Standards Association (CSA) A23.2-14C. Additionally, the cores were tested for water soluble sulphate content in

accordance with ASTM C114 and ASTM C1580. The results of the testing are provided in Table 3-1. The summary of the petrographic analysis and results of the compressive strength are enclosed in Appendix B.

Table 3-1: Concrete Core Summary

Core Number	Core Location	Saturated Surface Dry Density (kg/m ³)	Compressive Strength (MPa)	Water Soluble Sulphate Content in Hydraulic Cement (% by mass)
1	Mechanical Room – West Wall 500 mm N of S wall 400 mm above floor slab	2358	41.5	--
2	Gas Room – East Wall 1.2 m N of S wall 200 mm above floor slab	2384	--	--
3	Mechanical Room – East Wall 3.1 m N of S wall 300 mm above floor slab	2359	--	--
4	Mechanical Room – West Wall 450 mm N of S wall 125 mm above floor slab	2392	--	0.006% at 35 mm to 50 mm from interior wall surface
5	Mechanical Room – East Wall 3.0 m N of S wall 50 mm above floor slab	2371	45.7	--
6	Mechanical Room – Floor Slab 600 mm E of W wall 500 mm N of S wall	2353	23.6 ¹	0.23% at 0 mm to 15 mm from slab surface

NOTE: ¹It should be noted that based on the observed maximum coarse aggregate size of 40 mm in core 6, and in accordance with CSA A23.2-14C, Clause 5.1, “A core specimen for the determination of compressive strength shall have a diameter of at least three times the nominal maximum size of the coarse aggregate used in the concrete”, the compressive strength result provided herein for core 6 is only an indication, and must be qualified by the actual core diameter in the range of 70 mm. For the test results to be deemed reliable, a drilled core diameter of at least 120 mm would be required for the floor slab.

Based on the tested concrete densities, the concrete compressive strength is expected to be similar for all cores extracted from the walls. The concrete mix used for the slab-on-grade construction was likely lower specified strength at the time of the construction.

4.0 DISCUSSION OF RESULTS

Based on the site observations and results of the laboratory testing and analysis, the primary mode of failure is trace concrete delamination and paint loss. This mode of failure can be attributed to a form of physical sulphate attack.

The test results of the sulphate ion content in the interior of concrete walls of 0.006% is considered negligible, while at the surface the result of 0.23% of the slab exceeds the threshold for severe degree of sulphate exposure, as per CSA A23.1-14, Table 3, of 0.2%.

Two forms of sulphate attack are commonly seen. The first form of sulphate attack is physical, which has caused some concrete delamination in the lower portion of the walls, and the formation of crystalline sulphate minerals. The mechanism for deterioration of this physical sulphate attack is volume expansion of precipitating sulphates within the concrete, which imposes tensile forces within the concrete. As moisture infiltrates the concrete

elements, sulphate ions within the groundwater enter the concrete matrix; when the groundwater levels drop and the concrete dries up, the sulphate ions precipitate into a crystalline form which has an inherent volumetric expansion.

The second form of sulphate attack is chemical, which was not identified in the concrete wall and slab-on-grade at this time, however the potential exists based on the observed sulphates and the tested sulphate level within the concrete slab. The mechanism occurs when sodium sulphates infiltrating into the system react with the calcium aluminate hydrate in the concrete to form ettringite, and with calcium hydroxide to form gypsum and sodium hydroxide. The magnesium sulphates react with calcium silicate hydrate to form gypsum. The reaction of ettringite with magnesium hydroxide results in the formation of more gypsum. These reactions result in a total disintegration of cement paste with a large presence of gypsum. The physical mechanisms by which deterioration occurs are expansive formation of ettringite and/or gypsum in the hardened cement paste causing cracking and exfoliation, and the softening and dissolution of hydrated cementing compounds to a mush.

Salt crystallization is more severe at locations where the concrete is exposed more to wetting and drying cycles, such as near the walls and in trapped low areas on the slab. Elevated sulphate levels in the soils surrounding the subgrade mechanical room combined with a fluctuating groundwater table is exacerbating the sulphate attack potential. In periods of high groundwater, water-soluble sulphate ions are brought into the backfill soils; as the groundwater table then recedes, some of the sulphate ion precipitate, and remain in concrete or are precipitated in the lower portion of the walls or onto the slab.

The site observations and analysis and laboratory testing of the concrete cores indicated that the wall thickness after surface loss and delamination is not significant at this time. The compressive strength in the range of 41.5 MPa and the wall loss of up to 25 mm should be taken into consideration when determining the structural adequacy of the concrete wall; such structural analyses are beyond the scope of this investigation.

5.0 RECOMMENDATIONS

The sulphate attack observed in the mechanical room of the JT Foster School is considered minor at this time; however, the potential for further sulphate attack in both chemical and physical forms exists. The school was constructed in the 1960s and therefore the rate of concrete deterioration is considered slow and there is no evidence that the structural integrity of the walls is compromised.

Any rehabilitation of the interior surface of the walls will not stop the sulphate accumulation, as the sulphate is being introduced externally, but may increase the service life of the walls. Measures to lower the water table may not be practical but a membrane application on both sides of the affected walls would slow down the sulphate bearing moisture ingress to the walls. Since the concrete condition in the cores was good, the repairs are feasible; however, the logistics of placing a membrane on the outside of the mechanical room walls is not known.

The level of sulphates in the slab is considered severe; however, if repairs to the concrete walls are effective in eliminating the ingress of moisture and additional sulphate ions to the slab, sulphate attack is not expected to progress. Furthermore, if the slab is not structural, some degree of deterioration may be considered acceptable combined with a routine maintenance program.

The structural adequacy of the concrete walls (not related to concrete durability investigation) is beyond the scope of this investigation, and should be confirmed by a structural engineer.

Based on the results of the investigation, it is feasible to upgrade/renovate the facility and that the rate of the deterioration due to sulphate attack would not warrant any special remediation protocol.

6.0 LIMITATIONS OF REPORT

This report and its contents are intended for the sole use of Livingstone Range School District No. 68 and their agents. Tetra Tech EBA Inc. (Tetra Tech) does not accept any responsibility for the accuracy of any of the data, the analysis, or the recommendations contained or referenced in the report when the report is used or relied upon by any party other than Livingstone Range School District No. 68, or for any project other than the proposed development at the subject site. Any such unauthorized use of this report is at the sole risk of the user. Use of this report is subject to the terms and conditions stated in Tetra Tech's Services Agreement. Tetra Tech's General Conditions are provided in Appendix A of this report.

7.0 CLOSURE

We trust this report meets your present requirements. If you have any questions or comments, please contact the undersigned.

Respectfully submitted,
Tetra Tech EBA Inc.



Prepared by:
Jadon M. Pickett, B.Sc., E.I.T.
Project Engineer
Construction Services, Engineering Practice
Direct Line: 403.723.1546
jadon.pickett@tetrattech.com

Reviewed by:
Bozena Czarnecki, Ph.D., P.Eng.
Principal Specialist
Engineering Practice
Direct Line: 403.723.5950
bozena.czarnecki@tetrattech.com

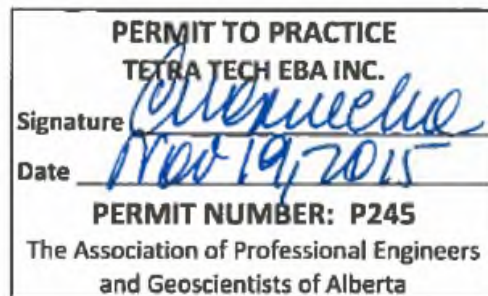

/dlc

APPENDIX A

TETRA TECH EBA'S GENERAL CONDITIONS

GENERAL CONDITIONS

CONSTRUCTION MATERIALS ENGINEERING AND TESTING DOCUMENT

This report incorporates and is subject to these “General Conditions”.

1.0 USE OF REPORT AND OWNERSHIP

This Construction Materials Testing, Materials Engineering, or Materials Design Reporting Document pertains to a specific site, a specific development, and a specific scope of work. The report may include field and/or laboratory tests and other support documents that collectively constitute the Materials Testing or Materials Design report. It is not applicable to any other sites or projects other than that to which it refers.

This report and the recommendations contained in it are intended for the sole use of Tetra Tech EBA's Client. Tetra Tech EBA does not accept any responsibility for the accuracy of any of the data, the analyses or the recommendations contained or referenced in the report when the report is used or relied upon by any party other than Tetra Tech EBA's Client unless otherwise authorized in writing by Tetra Tech EBA. Any unauthorized use of the report is at the sole risk of the user.

This report is subject to copyright and shall not be reproduced either wholly or in part without the prior, written permission of Tetra Tech EBA. Additional copies of the report, if required, may be obtained upon request.

2.0 ALTERNATE REPORT FORMAT

Where Tetra Tech EBA submits both electronic file and hard copy versions of reports, drawings and other project-related documents and deliverables (collectively termed Tetra Tech EBA's instruments of professional service), only the signed and/or sealed versions shall be considered final and legally binding. The original signed and/or sealed version archived by Tetra Tech EBA shall be deemed to be the original for the Project.

Both electronic file and hard copy versions of Tetra Tech EBA's instruments of professional service shall not, under any circumstances, no matter who owns or uses them, be altered by any party except Tetra Tech EBA. Tetra Tech EBA's instruments of professional service will be used only and exactly as submitted by Tetra Tech EBA.

Electronic files submitted by Tetra Tech EBA have been prepared and submitted using specific software and hardware systems. Tetra Tech EBA makes no representation about the compatibility of these files with the Client's current or future software and hardware systems.

3.0 ENVIRONMENTAL AND REGULATORY ISSUES

Unless stipulated in the report, Tetra Tech EBA has not been retained to investigate, address or consider and has not investigated, addressed or considered any environmental, regulatory, or sediment and erosion issues associated with construction on the subject site.

4.0 VARIATION OF MATERIAL CHARACTERISTICS AND CONDITIONS

Observations and standardized sampling, inspection and testing procedures employed by Tetra Tech EBA will indicate conditions of materials and construction activities only at the precise location and time where and when Services were performed. The Client recognizes that conditions of materials and construction activities at other locations may vary from those measured or observed, and that conditions at one location and time do not necessarily indicate the conditions of apparently identical material(s) at other locations and/or times.

Services of Tetra Tech EBA, even if performed on a continuous basis, should not be interpreted to mean that Tetra Tech EBA is observing, verifying, testing or inspecting all materials on the Project. Tetra Tech EBA is responsible only for those data, interpretations, and recommendations regarding the actual materials and construction activities observed, sampled, inspected or tested, and is not responsible for other parties' interpretations or use of the information developed. Tetra Tech EBA may make certain inferences based upon the information derived from these procedures to formulate professional opinions regarding conditions in other areas.

5.0 SAMPLING, OBSERVATION & TEST LOCATIONS

Unless specifically stated otherwise, the Scope of Services does not include surveying the Site or precisely identifying sampling, observation or test locations, depths or elevations. Sampling, observation and test locations, depths and elevations will be based on field estimates and information furnished by the Client and its representatives. Unless stated otherwise in the report, such locations, depths and elevations provided are approximate.

6.0 CONTRACTOR'S PERFORMANCE

Tetra Tech EBA is not responsible for Contractor's means, methods, techniques or sequences during the performance of its Work. Tetra Tech EBA will not supervise or direct Contractor's Work, nor be liable for any failure of Contractor to complete its Work in accordance with the Project's plans, specifications and applicable codes, laws and regulations. The Client understands and agrees that Contractor, not Tetra Tech EBA, has sole responsibility for the safety of persons and property at the Project Site.

7.0 NOTIFICATION AND LEVEL OF SERVICE

Unless the Client requests or the building code requires full-time services, the Client understands that services provided by Tetra Tech EBA are on an “On-Call” basis. The Client shall assume responsibility for adequate notification and scheduling of Tetra Tech EBA services. Tetra Tech EBA will make every reasonable effort to meet the Client's schedule, but will not guarantee service availability without direct confirmation from with the Client or their agent.

8.0 CERTIFICATIONS

The Client will not require Tetra Tech EBA to execute any certification regarding Services performed or the Work tested or observed unless: 1) Tetra Tech EBA believes that it has performed sufficient Services to provide a sufficient basis to issue the certification; 2) Tetra Tech EBA believes that the Services performed and Work tested or observed meet the criteria of the certification; and 3) Tetra Tech EBA has reviewed and approved in writing the exact form of such certification prior to execution of the Service Agreement. Any certification by Tetra Tech EBA is limited to the expression of a professional opinion based upon the Services performed by Tetra Tech EBA, and does not constitute a warranty or guarantee, either express or implied.

9.0 WEATHER AND PROTECTION OF MATERIALS

Performance of the Services by Tetra Tech EBA and/or its designated subcontractor may be delayed or excused when such performance is commercially impossible or impracticable as a result of weather events, strikes, shortages or other causes beyond their reasonable control which may also impact cost estimates.

Excavation and construction operations expose materials to climatic elements (freeze/thaw, wet/dry) and/or mechanical disturbance which can cause severe deterioration. Unless otherwise specifically indicated in this report, the walls and floors of excavations, and stockpiles, must be protected from the elements, particularly moisture, desiccation, frost action and construction activities.

10.0 CALCULATIONS AND DESIGN

Where Tetra Tech EBA has undertaken design calculations and has prepared project specific designs in accordance with terms of reference that were previously set out in consultation with, and agreement of, Tetra Tech EBA's client. These designs have been prepared to a standard that is consistent with industry practice. Notwithstanding, if any error or omission is detected by Tetra Tech EBA's Client or any party that is authorized to use the Design Report, the error or omission should be immediately drawn to the attention of Tetra Tech EBA.

11.0 INFLUENCE OF CONSTRUCTION ACTIVITY

There is a direct correlation between construction activity and structural performance of adjacent buildings and other installations. The influence of all anticipated construction activities should be considered by the contractor, owner, architect and prime engineer in consultation with a geotechnical engineer when the final design and construction techniques are known.

12.0 SAMPLES

The Client will provide samples for testing (at the Client's expense). Tetra Tech EBA will retain unused portions of samples only until such time as internal review is accomplished for intended purpose. Further storage or transfer of samples can be made at the Client's expense upon written request, otherwise samples will be discarded. The duration of sample retention must be discussed in advance.

13.0 GEOTECHNICAL CONDITIONS

A Geotechnical Report is commonly the basis upon which the specific project design or testing has been completed. It is incumbent upon Tetra Tech EBA's Client, and any other authorized party, to be knowledgeable of the level of risk that has been incorporated into the project design, in consideration of the level of the geotechnical information that was reasonably acquired to facilitate completion of the design.

If a Geotechnical Report was prepared for the project by Tetra Tech EBA or others, it will be referenced in the Construction Materials or Materials Design Report. The Geotechnical Report contains General Conditions that should be read in conjunction with these General Conditions for this Report.

14.0 INFORMATION PROVIDED TO TETRA TECH EBA BY OTHERS

During the performance of the work and the preparation of the report, Tetra Tech EBA may rely on information provided by persons other than the Client. While Tetra Tech EBA endeavours to verify the accuracy of such information when instructed to do so by the Client, Tetra Tech EBA accepts no responsibility for the accuracy or the reliability of such information which may affect the report.

APPENDIX B

LABORATORY TEST RESULTS

Petrographic Analysis of Concrete Core

ASTM C856

Project:	JT Nanton School - Concrete Evaluation	Sample No.:	Core 1
Project Number:	LGEO03028-01	Date Received:	November 6, 2015
Client:	Livingstone Range School Division No. 68	Date Examined:	November 10, 2015
Sample Location:	Mechanical Room, West Wall	Petrographer:	JP
Overall Length:	245 mm		
Diameter:	95 mm		

Aggregate	Aggregate Maximum Size:	20 mm
	Aggregate Shape:	Subrounded with some fractured faces
	Composition:	Predominantly carbonate and quartzite with traces of sandstone and ironstone
	Gradation/Proportion:	Well graded, approximately 60% to 70% by volume
	Other:	
Concrete/Paste	Degree of Consolidation:	Well consolidated
	Condition of Cement Paste:	Competent
	Entrained Air:	Non air-entrained
	Bleeding Voids:	Good
	Aggregate/Paste Bond:	None identified
	Alkali Silica Reaction:	No chemical attack identified; trace sulphate
	Sulphate Attack:	precipitates observed
		None identified
	Freeze/Thaw Damage:	None identified
	Cracking/Fractures:	None identified
	Carbonation:	Not carbonated
	Other:	
Surface	Surface Condition:	Competent, painted surface
	Finishing:	Formed surface
	Other:	Paint well bonded to concrete
Reinforcement	Location:	None in core
	Size:	
	Reinforcement Condition:	
	Other:	
General		Overall competent concrete but may have the potential for sulphate attack.

Additional Tests:	SSD Density - 2358 kg/m ³
	Compressive Strength - 41.5 MPa

Photo

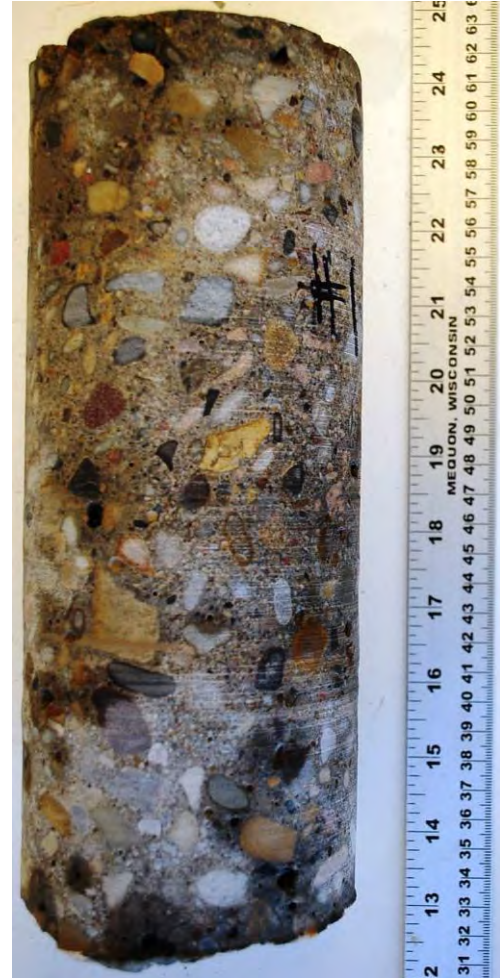

Reviewed By: *Quonichis* P.Eng.

Data presented hereon is for the sole use of the stipulated client. Tetra Tech EBA is not responsible, nor can be held liable, for use made of this report by any other party, with or without the knowledge of Tetra Tech EBA. The testing services reported herein have been performed to recognized industry standards, unless noted. No other warranty is made. These data do not include or represent any interpretation or opinion of specification compliance or material suitability. Should engineering interpretation be required, Tetra Tech EBA will provide it upon written request.

Petrographic Analysis of Concrete Core

ASTM C856

Project:	JT Nanton School - Concrete Evaluation	Sample No.:	Core 2
Project Number:	LGEO03028-01	Date Received:	November 6, 2015
Client:	Livingstone Range School Division No. 68	Date Examined:	November 10, 2015
Sample Location:	Gas Room, East Wall	Petrographer:	JP
Overall Length:	190 mm		
Diameter:	70 mm		

Photo



Aggregate	Aggregate Maximum Size:	20 mm
	Aggregate Shape:	Subrounded with some fractured faces
	Composition:	Predominantly carbonate and quartzite with traces of sandstone and ironstone
	Gradation/Proportion:	Well graded, approximately 60% to 70% by volume
	Other:	
Concrete/Paste	Degree of Consolidation:	Well consolidated
	Condition of Cement Paste:	Competent
	Entrained Air:	Non air-entrained
	Bleeding Voids:	Good
	Aggregate/Paste Bond:	None identified
	Alkali Silica Reaction:	No chemical attack identified; trace sulphate
	Sulphate Attack:	precipitates observed
		None identified
	Freeze/Thaw Damage:	None identified
	Cracking/Fractures:	None identified
	Carbonation:	Not carbonated
	Other:	
Surface	Surface Condition:	Competent, painted surface
	Finishing:	Formed surface
	Other:	Paint poorly bonded to concrete
Reinforcement	Location:	None in core
	Size:	
	Reinforcement Condition:	
	Other:	
General		Overall competent concrete but may have the potential for sulphate attack.

Additional Tests: SSD Density - 2384 kg/m³

Reviewed By: *Chromelis* P.Eng.

Data presented hereon is for the sole use of the stipulated client. Tetra Tech EBA is not responsible, nor can be held liable, for use made of this report by any other party, with or without the knowledge of Tetra Tech EBA. The testing services reported herein have been performed to recognized industry standards, unless noted. No other warranty is made. These data do not include or represent any interpretation or opinion of specification compliance or material suitability. Should engineering interpretation be required, Tetra Tech EBA will provide it upon written request.

Petrographic Analysis of Concrete Core

ASTM C856

Project:	JT Nanton School - Concrete Evaluation	Sample No.:	Core 3
Project Number:	LGEO03028-01	Date Received:	November 6, 2015
Client:	Livingstone Range School Division No. 68	Date Examined:	November 10, 2015
Sample Location:	Mechanical Room, East Wall	Petrographer:	JP
Overall Length:	160 mm		
Diameter:	70 mm		

Aggregate	Aggregate Maximum Size:	20 mm
	Aggregate Shape:	Subrounded with some fractured faces
	Composition:	Predominantly carbonate and quartzite with traces of sandstone and ironstone
	Gradation/Proportion:	Well graded, approximately 60% to 70% by volume
	Other:	
Concrete/Paste	Degree of Consolidation:	Well consolidated
	Condition of Cement Paste:	Competent
	Entrained Air:	Non air-entrained
	Bleeding Voids:	Good
	Aggregate/Paste Bond:	None identified
	Alkali Silica Reaction:	No chemical attack identified; trace sulphate
	Sulphate Attack:	precipitates observed
		None identified
	Freeze/Thaw Damage:	None identified
	Cracking/Fractures:	None identified
	Carbonation:	Not carbonated
	Other:	
Surface	Surface Condition:	Competent, painted surface
	Finishing:	Formed surface
	Other:	Paint fairly well bonded to concrete
Reinforcement	Location:	None in core
	Size:	
	Reinforcement Condition:	
	Other:	
General		Overall competent concrete but may have the potential for sulphate attack.

Additional Tests: SSD Density - 2359 kg/m³

Photo



Reviewed By: *Chromelis* P.Eng.

Data presented hereon is for the sole use of the stipulated client. Tetra Tech EBA is not responsible, nor can be held liable, for use made of this report by any other party, with or without the knowledge of Tetra Tech EBA. The testing services reported herein have been performed to recognized industry standards, unless noted. No other warranty is made. These data do not include or represent any interpretation or opinion of specification compliance or material suitability. Should engineering interpretation be required, Tetra Tech EBA will provide it upon written request.

Petrographic Analysis of Concrete Core

ASTM C856

Project:	JT Nanton School - Concrete Evaluation	Sample No.:	Core 4
Project Number:	LGEO03028-01	Date Received:	November 6, 2015
Client:	Livingstone Range School Division No. 68	Date Examined:	November 10, 2015
Sample Location:	Mechanical Room, West Wall	Petrographer:	JP
Overall Length:	180 mm		
Diameter:	70 mm		

Aggregate	Aggregate Maximum Size:	20 mm
	Aggregate Shape:	Subrounded with some fractured faces
	Composition:	Predominantly carbonate and quartzite with traces of sandstone and ironstone
	Gradation/Proportion:	Well graded, approximately 60% to 70% by volume
	Other:	
Concrete/Paste	Degree of Consolidation:	Well consolidated
	Condition of Cement Paste:	Competent
	Entrained Air:	Non air-entrained
	Bleeding Voids:	Good
	Aggregate/Paste Bond:	None identified
	Alkali Silica Reaction:	No chemical attack identified; trace sulphate
	Sulphate Attack:	precipitates observed
		None identified
	Freeze/Thaw Damage:	None identified
	Cracking/Fractures:	None identified
	Carbonation:	Not carbonated
	Other:	
Surface	Surface Condition:	Competent, painted surface
	Finishing:	Formed surface
	Other:	Paint well bonded to concrete
Reinforcement	Location:	None in core
	Size:	
	Reinforcement Condition:	
	Other:	
General		Overall competent concrete but may have the potential for sulphate attack.

Photo



Additional Tests:	SSD Density - 2392 kg/m ³
	Water Soluble Sulphate Content - 0.006%

Reviewed By: *Quonichis* P.Eng.

Data presented hereon is for the sole use of the stipulated client. Tetra Tech EBA is not responsible, nor can be held liable, for use made of this report by any other party, with or without the knowledge of Tetra Tech EBA. The testing services reported herein have been performed to recognized industry standards, unless noted. No other warranty is made. These data do not include or represent any interpretation or opinion of specification compliance or material suitability. Should engineering interpretation be required, Tetra Tech EBA will provide it upon written request.

Petrographic Analysis of Concrete Core

ASTM C856

Project:	JT Nanton School - Concrete Evaluation	Sample No.:	Core 5
Project Number:	LGEO03028-01	Date Received:	November 6, 2015
Client:	Livingstone Range School Division No. 68	Date Examined:	November 10, 2015
Sample Location:	Mechanical Room, East Wall	Petrographer:	JP
Overall Length:	240 mm		
Diameter:	95 mm		

Aggregate	Aggregate Maximum Size:	20 mm
	Aggregate Shape:	Subrounded with some fractured faces
	Composition:	Predominantly carbonate and quartzite with traces of sandstone and ironstone
	Gradation/Proportion:	Well graded, approximately 60% to 70% by volume
	Other:	
Concrete/Paste	Degree of Consolidation:	Well consolidated
	Condition of Cement Paste:	Competent
	Entrained Air:	Non air-entrained
	Bleeding Voids:	Good
	Aggregate/Paste Bond:	None identified
	Alkali Silica Reaction:	No chemical attack identified; trace sulphate
	Sulphate Attack:	precipitates observed
		None identified
	Freeze/Thaw Damage:	None identified
	Cracking/Fractures:	None identified
	Carbonation:	Not carbonated
	Other:	
Surface	Surface Condition:	Painted surface with some spalling
	Finishing:	Formed surface
	Other:	Paint well bonded to concrete
Reinforcement	Location:	None in core
	Size:	
	Reinforcement Condition:	
	Other:	
General		Overall competent concrete but may have the potential for sulphate attack.
	Additional Tests:	SSD Density - 2371 kg/m ³
		Compressive Strength - 45.7 MPa

Photo



Reviewed By: *Quonichu* P.Eng.

Data presented hereon is for the sole use of the stipulated client. Tetra Tech EBA is not responsible, nor can be held liable, for use made of this report by any other party, with or without the knowledge of Tetra Tech EBA. The testing services reported herein have been performed to recognized industry standards, unless noted. No other warranty is made. These data do not include or represent any interpretation or opinion of specification compliance or material suitability. Should engineering interpretation be required, Tetra Tech EBA will provide it upon written request.

Petrographic Analysis of Concrete Core

ASTM C856

Project:	JT Nanton School - Concrete Evaluation	Sample No.:	Core 6
Project Number:	LGEO03028-01	Date Received:	November 6, 2015
Client:	Livingstone Range School Division No. 68	Date Examined:	November 10, 2015
Sample Location:	Mechanical Room, Floor by West Wall	Petrographer:	JP
Overall Length:	180 mm		
Diameter:	70 mm		

Aggregate	Aggregate Maximum Size:	40 mm
	Aggregate Shape:	Subrounded with trace fractured faces
	Composition:	Predominantly carbonate and quartzite with traces of sandstone and ironstone
	Gradation/Proportion:	Well graded, approximately 60% to 70% by volume
	Other:	
Concrete/Paste	Degree of Consolidation:	Well consolidated
	Condition of Cement Paste:	Competent
	Entrained Air:	Non air-entrained
	Bleeding Voids:	Good
	Aggregate/Paste Bond:	None identified
	Alkali Silica Reaction:	No chemical attack identified; trace sulphate
	Sulphate Attack:	precipitates observed
		None identified
	Freeze/Thaw Damage:	None identified
	Cracking/Fractures:	None identified
	Carbonation:	Carbonated to depth of 50 mm
	Other:	Slab placed on poly moisture barrier
Surface	Surface Condition:	Competent
	Finishing:	Steel trowel smooth finish
	Other:	
Reinforcement	Location:	None in core
	Size:	
	Reinforcement Condition:	
	Other:	
General		Overall competent concrete but may have the potential for sulphate attack.
		Concrete is not consistent with that seen in the walls
	Additional Tests:	SSD Density - 2353 kg/m ³
		Compressive Strength - 23.6 MPa
		Water Soluble Sulphate Content - 0.23%

Photo



Reviewed By: *Armelis* P.Eng.

Data presented hereon is for the sole use of the stipulated client. Tetra Tech EBA is not responsible, nor can be held liable, for use made of this report by any other party, with or without the knowledge of Tetra Tech EBA. The testing services reported herein have been performed to recognized industry standards, unless noted. No other warranty is made. These data do not include or represent any interpretation or opinion of specification compliance or material suitability. Should engineering interpretation be required, Tetra Tech EBA will provide it upon written request.

COMPRESSIVE STRENGTH OF DRILLED CONCRETE CORES TEST REPORT

CSA A23.2-14C

Project: JT Nanton School **Client:** Livingstone Range School Division No. 68
Project No.: LGEO03028-01 **Supplier:** Unknown
Test Location: Mechanical Room **Specified Strength:** Unknown

Core Locations:
 Core 1 West Wall - approx 500mm North of South wall, 400mm above floor slab
 Core 5 East Wall - approx 3m North of South wall, 50mm above floor slab
 Core 6 Floor slab - approx 600mm East of West wall, 500mm North of South wall

Core No.	Placement		Cored		Tested		Test By	Curing Method	Mass in Air (g)	Mass in H ₂ O	Vol. (cm ³)	Density (kg/m ³)
	Date	Time	Date	Time	Date	Time						
1			6-Nov-15		12-Nov-15		KH				-	2358
5			6-Nov-15		12-Nov-15		KH				-	2372
6			6-Nov-15		12-Nov-15		KH				-	2353
											-	
											-	
											-	

Core No.	Dia. (mm)	Area (cm ²)	Capped Height (mm)	L/D Ratio	Correction Factor (L/D)	Ultimate Load (kN)	Ultimate Stress (MPa)	Corrected Stress (MPa)	Type of Fracture	Test Age	Type of Fracture	
											1	Cone
1	94.4	69.92	150.0	1.59	0.97	300	42.9	41.5	1		3	Columnar
5	94.6	70.21	158.0	1.67	0.97	330	47.0	45.7	1		4	Shear Diagonal
6	69.7	38.16	80.0	1.15	0.91	100	26.1	23.6	1		5	Single Edge
											6	End
											ST	Splitting Tensile

Remarks:



Reviewed By: *Quonichu* P.Eng.

Data presented hereon is for the sole use of the stipulated client. Tetra Tech EBA is not responsible, nor can be held liable, for use made of this report by any other party, with or without the knowledge of EBA. The testing services reported herein have been performed to recognized industry standards, unless noted. No other warranty is made. These data do not include or represent any interpretation or opinion of specification compliance or material suitability. Should engineering interpretation be required, EBA will provide it upon written request.



JT Foster School

Lethbridge, Alberta

**MAIN DISTRIBUTION BOARD
DUE DILIGENCE REVIEW**

**SMP Engineering
234 – 13th Street North
Lethbridge, Alberta**

**Evaluation Team
Brian King/Dale Krall**

Table of Contents

<u>Section</u>	<u>Page</u>
Executive Summary-----	3
Methodology -----	3
Description of Existing System -----	3
Discussion -----	4
Recommendations -----	4
Photographs -----	5
References -----	7

JT Foster School
Main Distribution Board Due Diligence Review

Executive Summary

SMP Engineering has been commissioned to evaluate the existing Main Distribution Board (MDP) at JT Foster School located at:

2501 22nd Street, Nanton, Alberta

The goal of this study is to determine the state of the distribution board and assess damage sustained as the result of water infiltration into the mechanical room that the board is located in. The following key items were focused on:

- Review of distribution board location.
- Review of damage to the distribution board.
- Recommendations for system upgrades.

It shall be noted that the building observations and recommendations contained within this report are from an electrical perspective only. This report does not contain code reviews or recommendations from a mechanical consultant, structural consultant, or an architect.

The study determined the existing main distribution board is in very poor condition and should be replaced. Consideration should be given to relocating the distribution board to a location above grade where it is protected from contact with water and flooding.

Methodology

A site visit was performed to document the existing distribution board and location. Covers were removed in order to inspect the inside of the enclosure. The results of this site visit and photographs collected are contained in this report.

Description of Existing System

The existing MDP for this building is located in the Mechanical Room that is situated below grade. The MDP serves as the main electrical service for the entire building and contains distribution breakers as well as current transformers associated with utility metering. All other branch circuit panels and mechanical equipment are feed from this distribution board.

The MDP consists of 600A, 120/208V, 3 phase, 4 wire distribution board and 500A overcurrent protection. The following single line diagram illustrates the existing topography.

JT Foster School
Main Distribution Board Due Diligence Review

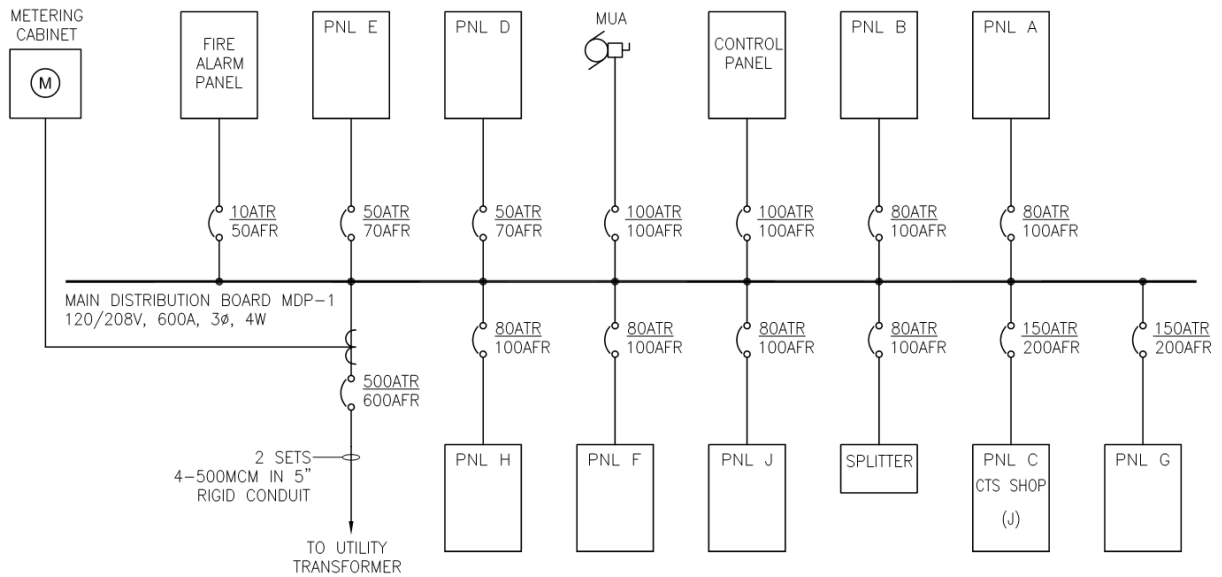

Figure 1: Existing Conditions Single Line Diagram

Discussion

Indoor electrical distribution components are typically designed for a life cycle of 30 to 40 years under normal operating conditions. Exposures to water damage and regular preventative maintenance programs have significant influence on the reduction or extension of expected life cycle. Periodic changes in code requirements and technological innovations lead to new system designs resulting in older equipment eventually becoming obsolete. Serviceability of older systems is compromised by the limited availability of obsolete parts and lack of service personnel trained to maintain older systems. The estimated year of installation of the distribution board is 1962 and is well beyond its expected life cycle.

It has been determined that the distribution board has sustained a large amount of damage from sustained contact with water on multiple occasions. The base of the distribution enclosure shows significant rusting and deterioration. The current location of the distribution board is clearly inappropriate for safe operation of electrical equipment. Should water enter the mechanical room again in the future and reach a level in which it comes in contact with the electrical bussing a short circuit or dangerous fault condition could result and significant damage could occur.

Recommendations

The existing distribution board is well beyond its expected life cycle and has sustained significant damage from contact with water. The distribution board should be replaced in the near future. When a replacement project is undertaken careful consideration should be given to the relocation of the main service. An alternative location should be selected where it will not be in danger of coming into contact with water.

JT Foster School
Main Distribution Board Due Diligence Review

Photographs



Photograph #1



Photograph #2

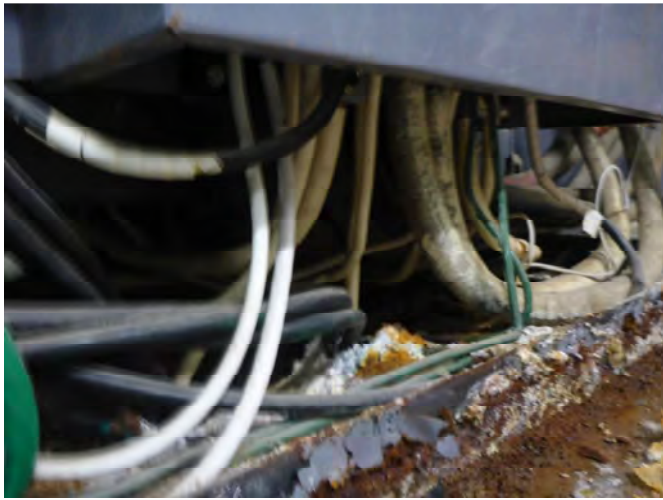

Photograph #3



Photograph #4

JT Foster School
Main Distribution Board Due Diligence Review

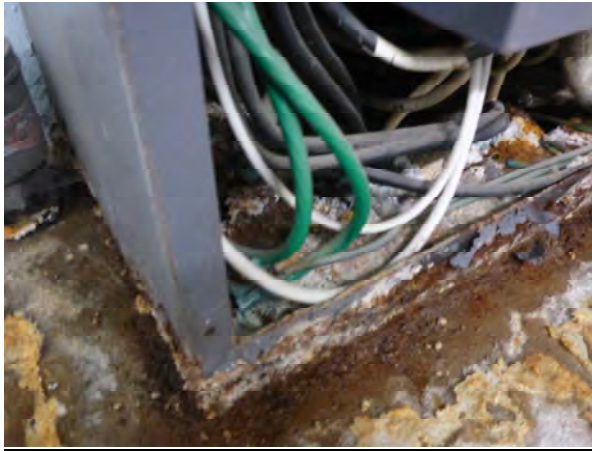

Photograph #5



Photograph #6

JT Foster School Main Distribution Board Review



Report Date: September 25, 2015
SMP Engineering File No: 15-02-0040
Prepared for: JT Foster School, Nanton, Alberta
Prepared By: SMP Engineering
Reporting Engineer: Dale L. Krall
Reviewing Engineer: Brian King

Reporting Engineer:

Dale L. Krall,
P. Eng, C.M.E, LEED® AP

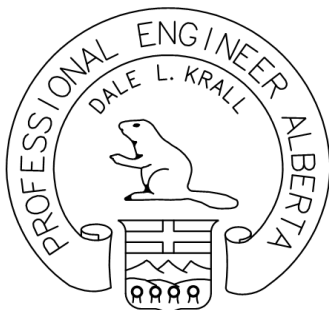

PERMIT NUMBER: P-5622

Reviewed By:

Brian King,
P. Eng., Partner

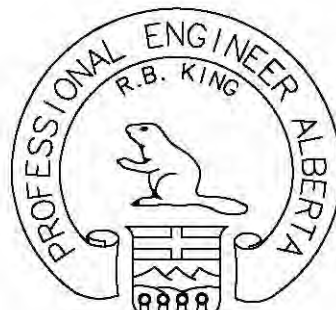

References

- Alberta Building Code 2006 Volume 1 & 2
- CSA C22.1-12 Canadian Electrical Code Part I